

Features

- Protection of Charger Reverse Connection
- Protection of Battery Cell Reverse Connection
- Over-temperature Protection
- Overcharge Current Protection
- Two-step Overcurrent Detection:
- Over Discharge Current
- Load Short Circuiting
- Charger Detection Function
- 0V Battery Charging Function
- RoHS Compliant and Lead (Pb) Free
- 40mΩ Low $R_{SS(ON)}$ Internal Power MOSFET
- Delay Times are generated inside
- High-accuracy Voltage Detection
- Low Current Consumption
- Operation Mode: 2.5μA typ.
- Power-down Mode: 1.5μA typ.
- Only One External Capacitor Required
- Available in DFN2x2-6 Package
- 40°C to +85°C Temperature Range

Applications

- One-Cell Li-ion Battery Pack
- Power Bank
- One-Cell Li-poly Battery Pack
- IOT Sensor/Electronic Toys

General Description

The TCS9922 is a high integration solution for lithium-ion/polymer battery protection. TCS9922 contains internal power MOSFET, high-accuracy voltage detection circuits and delay circuits. TCS9922 has all the protection functions required in the battery application including overcharging, over discharging, overcurrent and load short circuiting protection etc. The accurate overcharging detection voltage ensures safe and full utilization charging. The low standby current drains little current from the cell while in storage. The device is not only targeted for digital cellular phones, but also for any other Li-Ion and Li-Poly battery-powered information appliances requiring long-term battery life.

The TCS9922 requires a minimal number of readily available, external components and is available in a space saving DFN2x2-6 package.

Typical Application Circuit

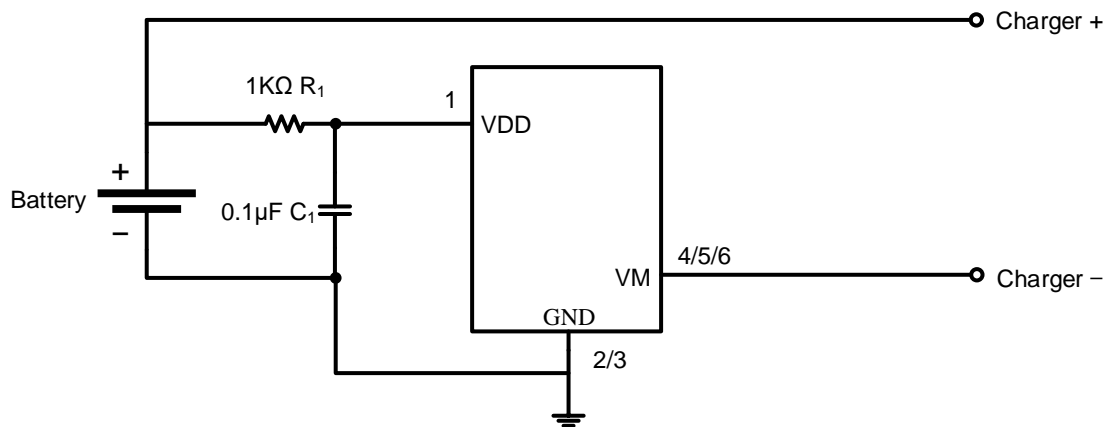

Figure 1. Typical Application Circuit