

BV_{DSS}	R_{DS(on)}	I_D
30V	3.2mΩ	45A

Features

- 1、 Low R_{DS(on)} to Minimize conduction Losses.
- 2、 High power package (DFN3030)
- 3、 Pb-Free Halogen Free and RoHS compliant
- 4、 Fast Switching Speed
- 5、 100% avalanche tested

Applications

- 1、 Buck-boost
- 2、 Half-bridge synchronous rectification
- 3、 Computer for DC to DC Converters Applications.
- 4、 Motor drive control

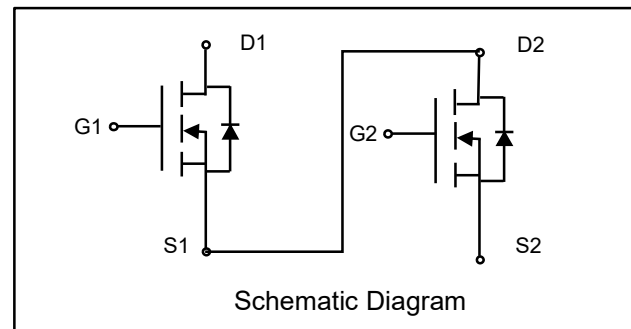
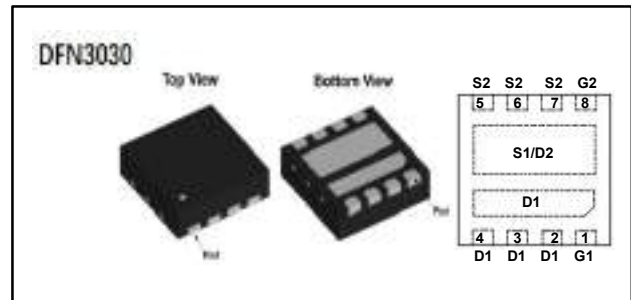

Packaging Specifications

Packing	Marking	Reel Size	Tape width	Basic ordering unit	Taping code
Embossed Tape		Ø180mm	8mm	3000	

Absolute Maximum Ratings (T_C=25°C unless otherwise noted)

Symbol	Parameter	Value	Unit
V _{DS}	Drain-Source Voltage (V _{GS} =0V)	30	V
V _{GS}	Gate-Source Voltage (V _{GS} =0V,static)	±20	V
I _D	Continuous Drain Current (T _C =25°C)	45	A
	Continuous Drain Current (T _C =100°C)	29	A
I _{DM} Note1	Pulesd Drain Current	120	A
I _{AS}	Avalanche Current	32	A
E _{AS} Note5	Single Pulsed Avalanche Energy	70	mJ
P _D	Maximum Power Dissipation (T _C =25°C)	30	W
	Maximum Power Dissipation (T _C =100°C)	11	W
T _J , T _{STG}	Operating, Storage Temperature Range	-55~150	°C

Thermal Characteristics

Symbol	Parameter	Max.	Unit
R _{θJA} Note2	Thermal Resistance, Junction-to-Ambient	70	°C/W
R _{θJC}	Thermal Resistance, Junction-to-Case	4.2	°C/W