

Description

TCS9224B can disconnect the systems from its output pin (OUT) in case wrong input operating conditions are detected. The system is positive overvoltage protected up to 36V. The internal over voltage thresholds (OVLO) is 6.1V and internal over current thresholds (OCP) is adjustable by an external resistor from 0.5A to 2.5A.

TCS9224B also has ENB function to turn on or off OUT, It also integrate internal over temperature protect (OTSD) function and it can monitor chip temperature to protect the device. The device is packaged in advanced full-Green Packaging.

Features

- Typical Ron: 120mΩ@1.0A
- VIN Operating Range: 2.5 to 36V
- Internal Overvoltage Lockout: 6.1V
- Adjustable Current Limited
- OVP Response time: 50ns (typ.)
- Output Discharge
- Startup Debounce Time: 8ms
- Output Power on time: 8ms
- Internal OTSD Protection
- ENB Pin Control
- SOT23-6 Package

Applications

- GPS
- MID
- SLR Digital Cameras
- Industrial Handheld and Enterprise Equipment

Typical application circuit

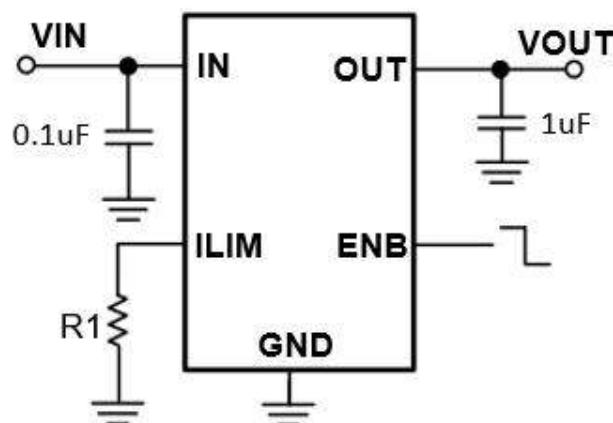

Device Information

Part No.	Package	Quality	Operation Temp.
TCS9224B_F	SOT23-6	3000	-40°C ~ 85°C

Pin Descriptions

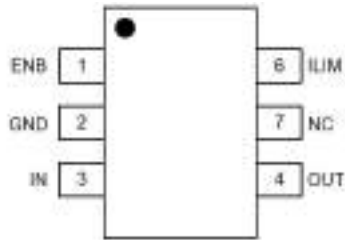

NAME	SOT23-6	TYPE	DESCRIPTION
ENB	1	I	Chip enable pin, Active Low
GND	2	P	Power ground
IN	3		Input pin, connect to AC adaptor or VBUS. A 0.1uF low ESR ceramic capacitor or larger must be connected as close as to this pin. It is recommended to use 50V capacitor or according to application.
OUT	4	O	Output pin, Connect to load.
NC	5	NC	No Connection
ILIM	6	I	Current Program pin, Connection a resistor to ground

Directions: I = input, O = output, OZ = tri-state output, OD = open-drain output, IO = input/output

Function Block Diagram

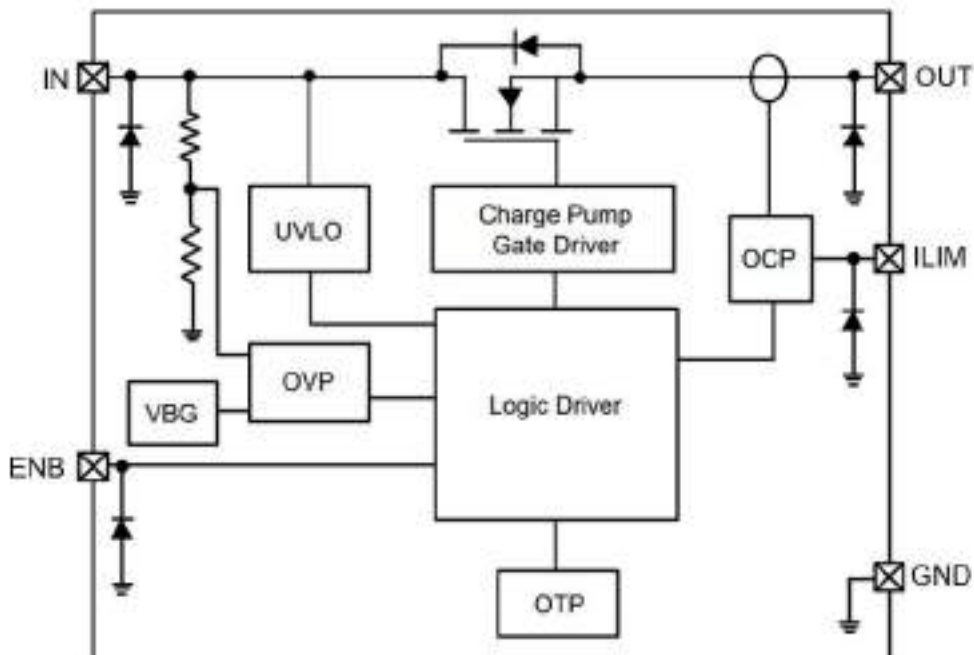

Absolute Maximum Ratings (TA=25°C)

Parameter		Min.	Max.	Unit
Input voltage (IN pin)	V _{IN}	-0.3	36	V
Output voltage (OUT pin)	V _{OUT}	-0.3	7.0	V
Power dissipation	PD		0.5	W
Thermal resistance	SOT23-6 θ_{JA}	260		°C/W
	DFN2X2-8 θ_{JA}	50		°C/W
ESD(HBM)		4.0		kV
Operation temp.	T _J	-40	150	°C
Storage temp.	T _{stg}	-65	150	°C

Recommended operating conditions (TA=25°C)

Parameter		Min.	Max.	Unit
Input voltage (IN pin)	V _{IN}	3.0	28.0	V
Output voltage (OUT pin)	V _{OUT}	0	5.5	V
Output Contiguous Current	I _{OUT}	0	1.5*	A

Notes: * Using 25mm² FR4 Signal layer PCB (1 oz) under VM=5.0V test.

Electrical Characteristics (V_{IN}=5V, T_A=25°C, R_{LOAD}=20)

over operating free-air temperature range (unless otherwise noted)

Parameter		Test Condition	Min.	Typ.	Max.	Unit
DC characteristics and Power-ON-Reset						
VIN operating voltage	V _{IN}		2.5		36	V
VIN operating supply current	I _{VIN_ON}	V _{IN} =5V, ENB=0		160	250	uA
	I _{VIN_OFF}	V _{IN} =5V, ENB=5V		0	2	uA
VIN-to-VOUT ON resistance	R _{ON}	V _{IN} =5V, I _{OUT} =0.1A		110		mΩ
		V _{IN} =5V, I _{OUT} =1.0A		120		mΩ
Output discharge resistance	R _{DIS}			500		Ω
VIN undervoltage lockout	V _{UVLO_R}	VIN rising		2.20		V
	V _{UVLO_F}	VIN falling		1.90		V
Output power on time	T _{ON}	V _{IN} = 0 -> 5V to output ON		8		ms
Input Over-Voltage Protection (OVP)						
VIN OVLO Protection	V _{OVLO_R}		5.8	6.1	6.4	V
Input low level voltage	V _{OVLO_HYS}			150		mV
OVP active time	T _{OVP}	V _{IN} = 5 -> 10V with rising 1V/20ns		50		ns
OVP recovery time	T _{ON_OVP}	V _{IN} = 10 -> 5V to output ON		8		ms
Input Over-Current-Protection (OCP)						
OCP threshold	I _{OCP}	R _{ILIM} =49.9k		2.05		A
		R _{ILIM} =69.8k		1.56		A
		R _{ILIM} =390k		0.55		A
OCP Active time	T _{OCP}			200		us
ILIM Voltage	V _{ILIM}			0.8		V
OCP recovery time	T _{OCP_RETRY}			1		S
Over-Temperature-Protection (OTP)						
OTP threshold	T _{OTP}			165		°C
OTP threshold hysteresis	T _{OTP_HYS}			40		°C

Functional Description

The OVP switch with overvoltage protection feature a low 120mΩ (typical) on-resistance (RON) internal FET and protect low-voltage systems against voltage faults up to 36VDC. If the input voltage (VIN) exceeds 6.1V, or input current exceeds 2.5A, the internal FET is quickly turned off to prevent damage to the protected downstream components.

The internal FET turns off when the junction temperature exceeds +165°C (TYP.). The device exits thermal shutdown after the junction temperature cools by 40°C (TYP.).

Input Capacitor

To limit the voltage drop on the input supply caused by transient inrush current when the switch turns on into a discharged load capacitor or short-circuit, a capacitor 1μF or larger must be placed between the VIN and GND pins.

Output Capacitor

A 1μF or larger capacitor should be placed between the OUT and GND pins.

Under-voltage Lockout (UVLO)

The under-voltage lockout (UVLO) circuit disables the power switch until the input voltage reaches the UVLO turn on threshold. Built-in hysteresis prevents unwanted on and off cycling because of input voltage droop during turn on.

Over Current Protection (OCP)

If the load current rises to the OCP threshold, the device will cut off the output voltage. It takes 8ms after power on for OCP begins to detect. After Power Good, the OCP active time is dozens to hundreds microseconds.

The OCP threshold is calculated by the equation:

$$I_{OUT} = 85/R_{LIM} + 340\text{mA} \text{ (current in A, resistance in k}\Omega\text{)}$$

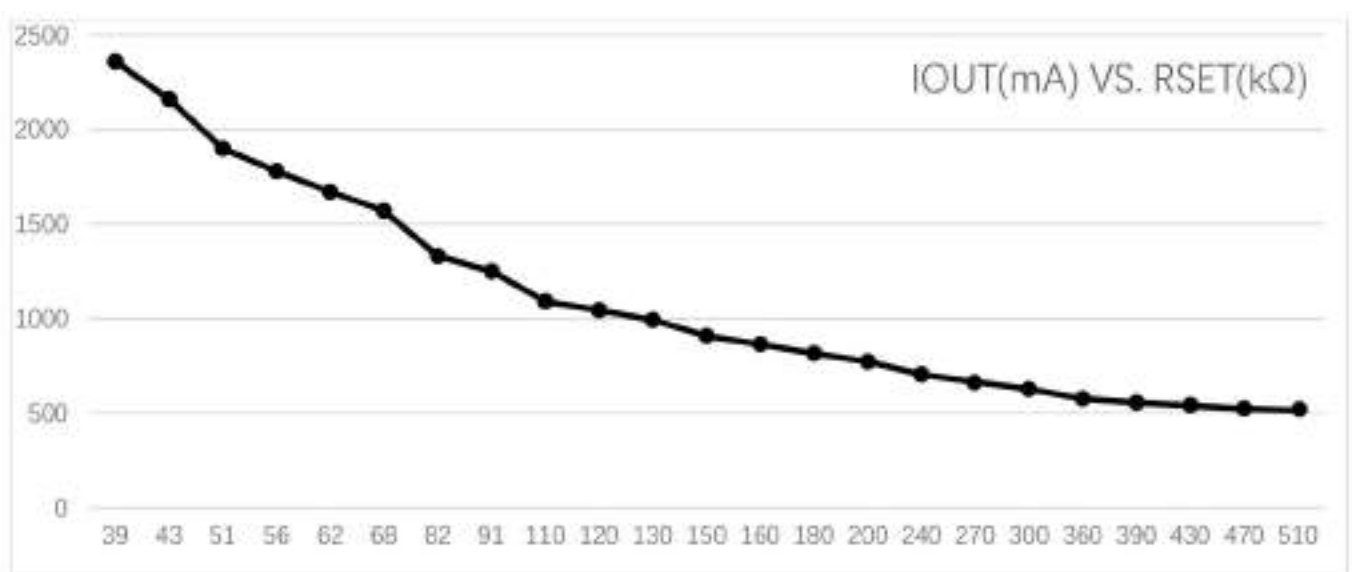

Package
SOT23-6

